



PAUMELLES EN ZAMAK 64 X 50 MM

72-1-9002

Rondelle en nylon.
Broche en acier.

A	64 mm
Note	type 2
Matière	zamak

Poids (g)	243 g
B	50 mm
C	17.5 mm
Finition	noir

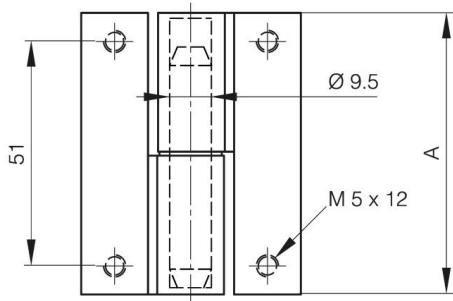

72-1-9003

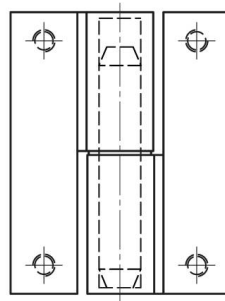

72-1-9002

