



VISIBLE SPRINGLOADED LATCHES - BOLT "NOSE-DOWN

16-1-3437

Slam latches.

A	70 mm
Material	brass

Weight (g)	163 g
B	73 mm
C	2.0 mm
S (hole diameter)	7 mm
E (knuckle or thickness)	22 mm
D (pin diameter)	1.5
F (pitch)	28 mm
G (pitch)	45 mm
H (height or starting holes)	38 mm
Finish	chrome plated
J	16 mm

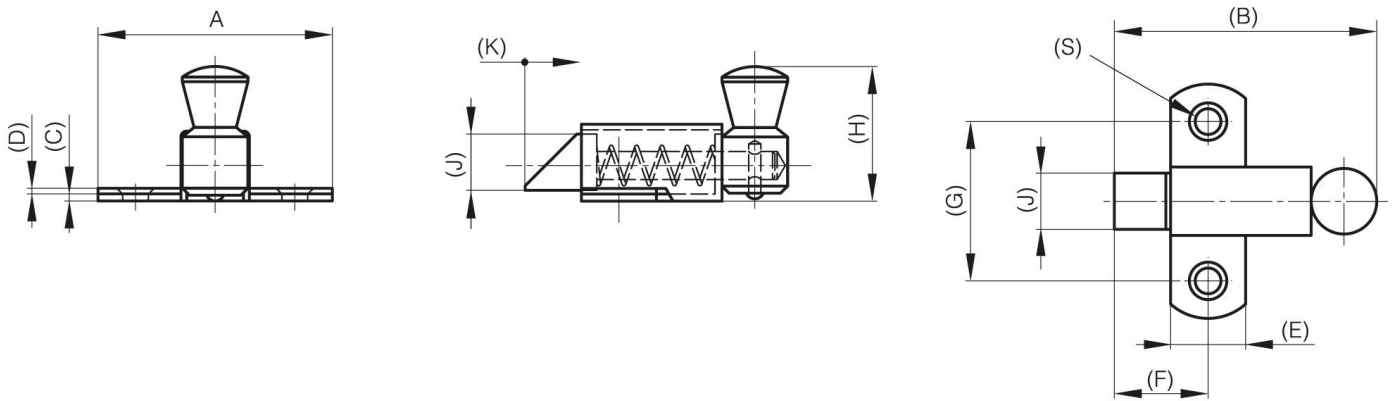

K	16 mm
----------	-------