



## **VISIBLE SPRINGLOADED LATCHES - BOLT "NOSE-DOWN"**

**16-1-3436**

Slam latches.

<b>A</b>	70 mm
<b>Material</b>	steel

<b>Weight (g)</b>	129 g
<b>B</b>	73 mm
<b>C</b>	2.0 mm
<b>S (hole diameter)</b>	7 mm
<b>E (knuckle or thickness)</b>	22 mm
<b>D (pin diameter)</b>	1.5
<b>F (pitch)</b>	28 mm
<b>G (pitch)</b>	45 mm
<b>H (height or starting holes)</b>	38 mm
<b>Finish</b>	zinc plated
<b>J</b>	16 mm

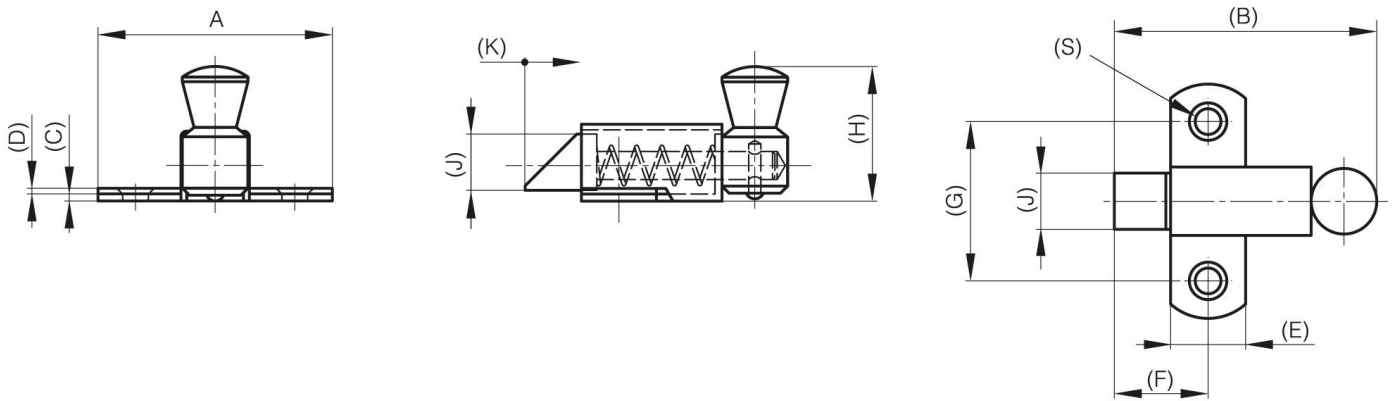

<b>K</b>	16 mm
----------	-------